

4322.**

6.3 (.250) TYPE SERIES · RECEPTACLES FOR CONNECTOR



Specification Standard Terminals

For male (mm) 6,3x0,8

Din Esp

Wire size mm² (AWG) 0,3-0,6 (22-20)

Ø Insulation (mm) 1,4-2,1

Materials, temperature and contact resistance

Part nr.	Material	Finishing	Max. Temp. (°C)
4322.00	Brass	Natural	110
4322.02	Brass	Tin plated	120

Material thickness (mm) 0,32

Max. rated current

Wire section	4322.00 / 02
0.30 mm ²	2A
0.35 mm ²	4A
0.50 mm ²	5A
0.60 mm ²	5A

Insertion / Withdrawal forces

	4322.00 / 02
1st Insertion (max)	30N ¹
1st Withdrawal (max)	60N ¹
6th Insertion (min)	10N ¹

¹ Valid for Natural Brass Tab

Application tool MN4322

Wire strip length 5.0 (±0.5) mm

Crimping parameters & pull out force

Wire section (±10%)	Conductor		Insulator	Pull-out force (N)
	Height (mm)	Width (mm)	Width (mm)	
0.30 mm ²	1.00 (±0.03)	1.85 (±0.03)	2.66 (±0.10)	28N @ 60s
0.35 mm ²	1.05 (±0.03)	1.85 (±0.03)	2.66 (±0.10)	40N @ 60s
0.50 mm ²	1.10 (±0.03)	1.85 (±0.03)	2.66 (±0.10)	56N @ 60s
0.60 mm ²	1.10 (±0.05)	1.85 (±0.05)	2.67 (±0.10)	56N @ 60s

Values only valid for the application tool specified upwards. The insulator widths are only indicative as they are dependent on the sheath thickness of the wire used.

Winding number 9000

Compatible connectors 26374**, 26387**

Approvals



4322.**

6.3 (.250) TYPE SERIES · RECEPTACLES FOR CONNECTOR



Drawing

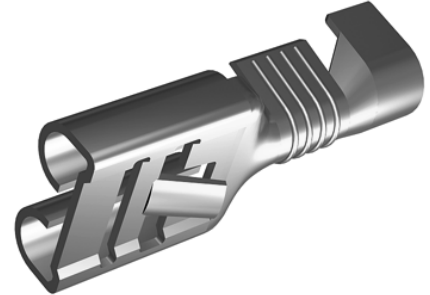
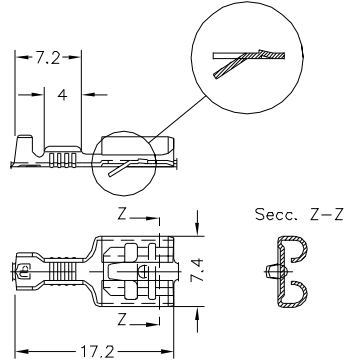

Disclaimer

Data obtained from Escubedo Laboratory essays, using own methodology, cablings, equipment and original crimping tools, done in laboratory conditions and following the indicated standards, errors and omissions excepted. This document has no contractual meaning and it is publicised only for informative purposes. It can be changed without prior notice. The end customer has the sole responsibility to check these characteristics in its environment and with its own components, manufacturing methods and equipment. See also the full range product overview if available. For further information please visit our web site or contact us

Rev. Nr.	Concept	Date	Created/Revised	Approved
A1	Datasheet generated automatically [A1]	2025-08-05	Laboratory dept.	E. Roura (laboratory dept.)

Escubedo Connection Systems, S.A.U. · 17843 Riudellots de la Creu · Girona · Spain
Tel.: 34 972 171 706 · Fax: +34 972 171 714 · info@escubedo.com · www.escubedo.com