

DETAIL B
SCALE 5 : 1

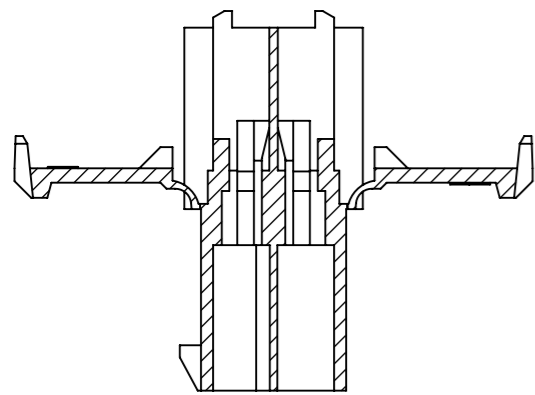

SECTION A-A

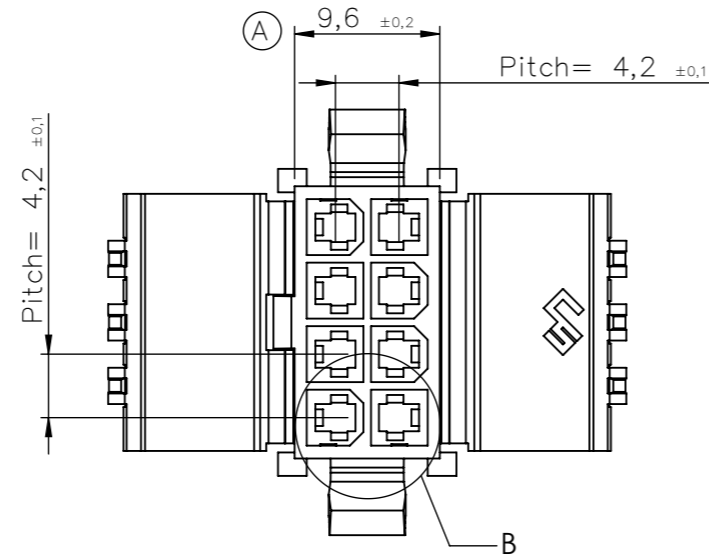
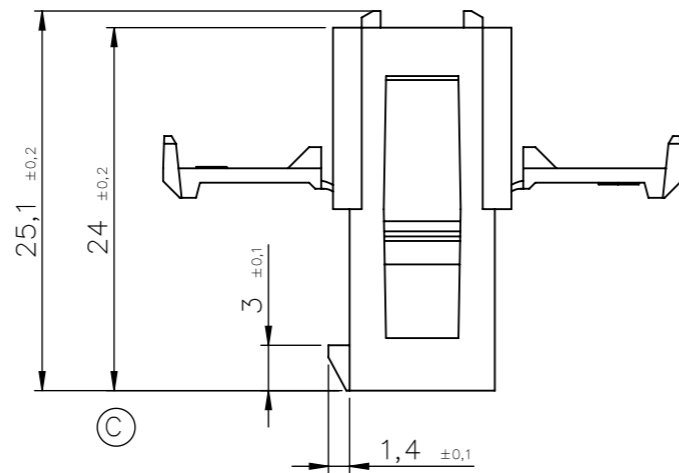

SECTION C-C

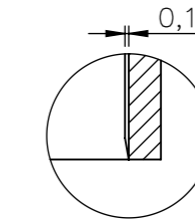
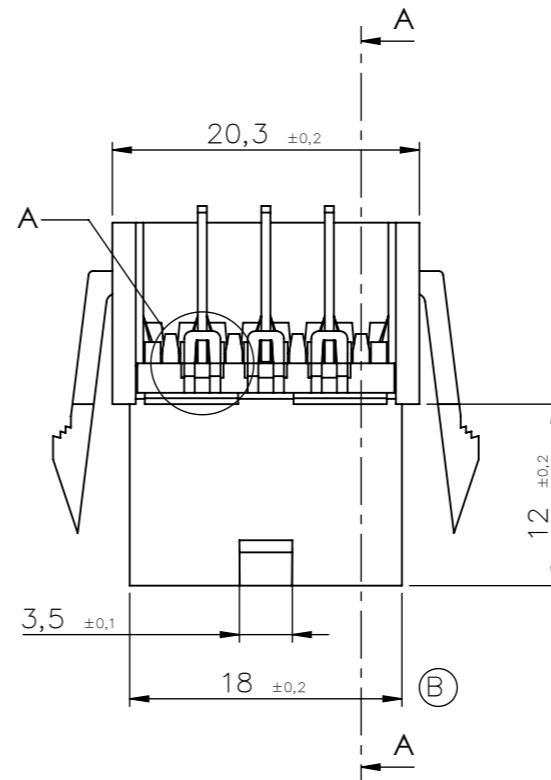

DETAIL C
SCALE 5 : 1

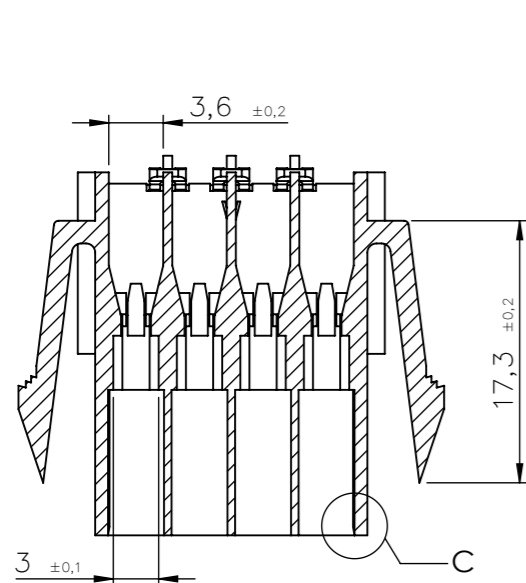

SECTION B-B

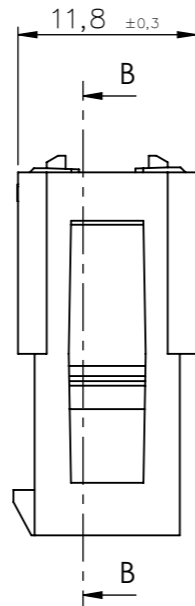

SECTION B-B

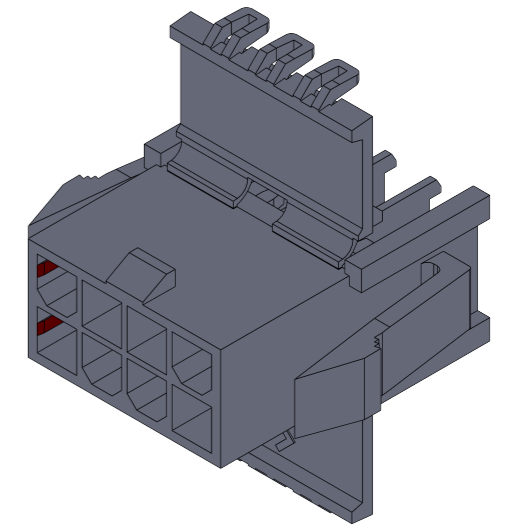

NOTES

GENERAL NOTES

Refer to 3D for missing dimensions. In case of doubt, ask before interpretate any dimension.

SYMBOLS DEFINITION

⊗ Control dimension

06	O.Roura	Suppress mat. 45	10/03/25
05	-	Version 3.5->3.7	27/04/17
04	-	242F2460/50	26/04/16
03	-	Mat. 15%GF	11/07/14
02	-	Material	29/05/14
01	-	Fecha	14/04/14
00	V.Roura	Ref/Añ.pinza	16/01/12
		1º Edición	

Part Number	Finish	Material	Ways	Rev	Name	Modification	Date
242FP2480	Natural	PAV2NF	2x4w				
242FP2460	Natural	PAV0NF					
242FP2440	Natural	PAV2GFNF					
242FP2430	Natural	PAV0					
242FP2410	Natural	PAV2					

			<p>PANEL MOUNT MALE HOLDER PITCH 4.2 mm – UPFIT</p>					
DRAWN	V.Roura	16/01/12	MATERIAL STANDARDS		DIMENSIONAL STANDARDS		GENERAL TOLERANCES	
REVISD	F.Adamuz	16/01/12	Special		Special		±0,25	
SCALE	2:1						REF. 242FP24xx r06	
			FORMAT		A3h		DRAWING	
							PTC-c572	