

DETAIL B
SCALE 5 : 1

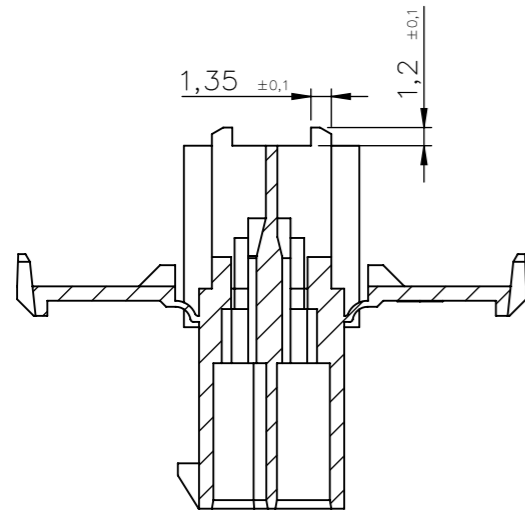

SECTION A-A

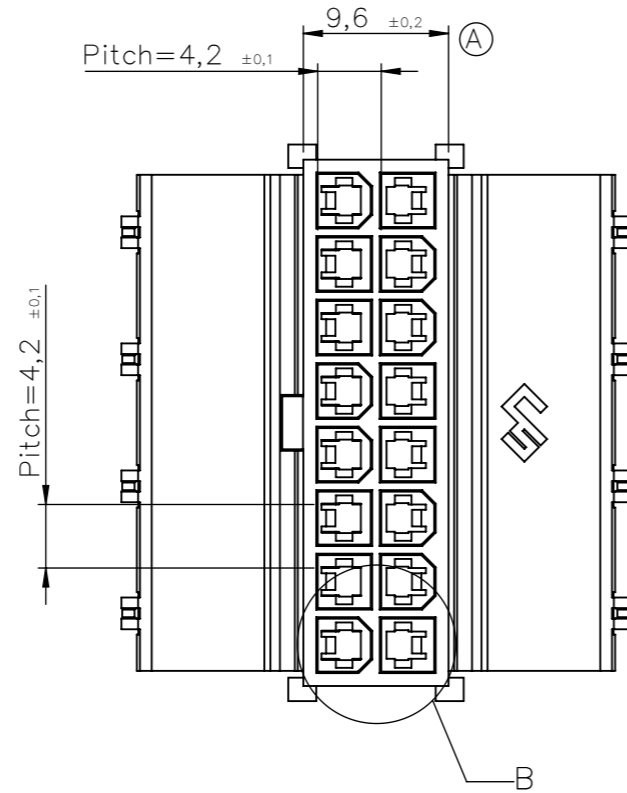
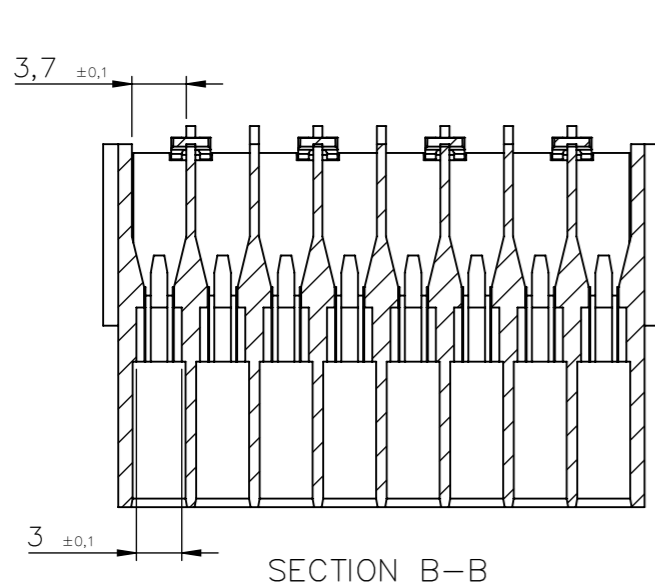
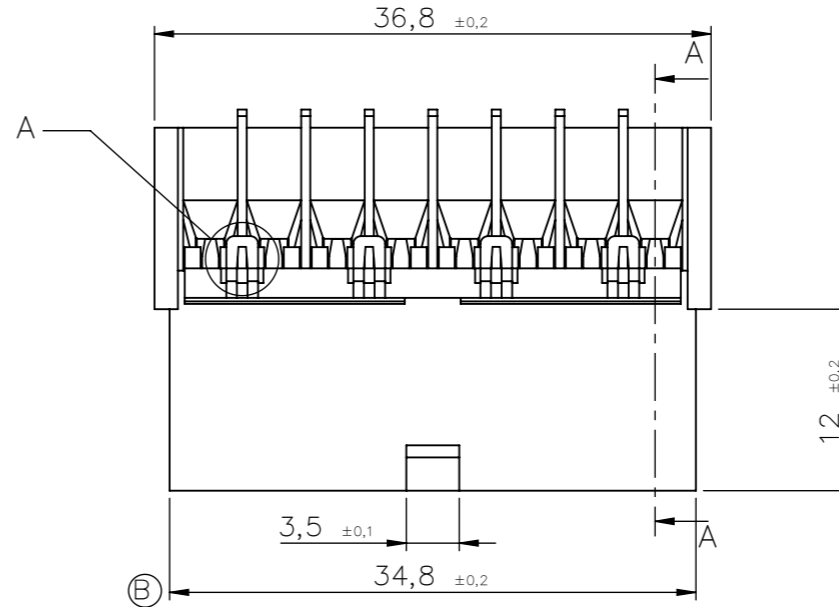
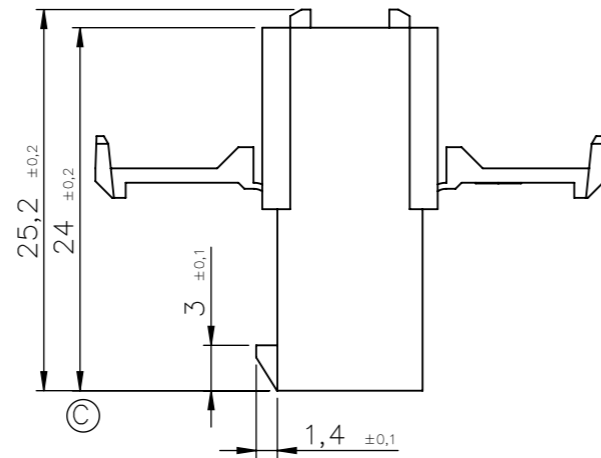

SECTION B-B

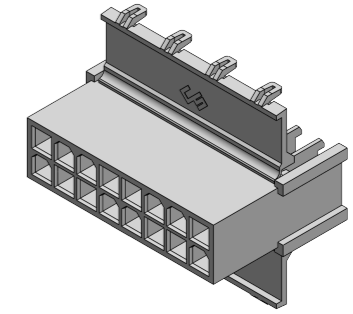
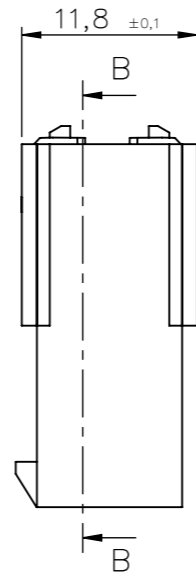

NOTES

GENERAL NOTES

Refer to 3D for missing dimensions. In case of doubt, ask before interpretate any dimension.

SYMBOLS DEFINITION

⊗ Control dimension

Part Number	Finish	Material	Ways	Rev	Name	Modification	Date
242F2880	Natural	PAV2NF	2x8w	05	O.Roura	Update dimensions	21/05/26
242F2860		PAV0NF		04	O.Roura	Suppress mat. 45 Version 3.5->3.7	24/04/26
242F2840		PAV2GFNF		03	-	242F2860/80	27/04/17
242F2830		PAV0		02	-	Mat.15%GF	26/04/16
242F2810		PAV2		01	-	Mat.7%GF /Fechador	16/06/14
				00	V.Roura	1ªEdición	06/03/14

Part Number	Finish	Material	Ways	Rev	Name	Modification	Date
242F2880	Natural	PAV2NF	2x8w	05	O.Roura	Update dimensions	21/05/26
242F2860	Natural	PAV0NF	2x8w	04	O.Roura	Suppress mat. 45 Version 3.5->3.7	24/04/26
242F2840	Natural	PAV2GFNF	2x8w	03	-	242F2860/80	27/04/17
242F2830	Natural	PAV0	2x8w	02	-	Mat.15%GF	26/04/16
242F2810	Natural	PAV2	2x8w	01	-	Mat.7%GF /Fechador	16/06/14
				00	V.Roura	1ªEdición	06/03/14

Part Number	Finish	Material	Ways	Rev	Name	Modification	Date
242F2880	Natural	PAV2NF	2x8w	05	O.Roura	Update dimensions	21/05/26
242F2860	Natural	PAV0NF	2x8w	04	O.Roura	Suppress mat. 45 Version 3.5->3.7	24/04/26
242F2840	Natural	PAV2GFNF	2x8w	03	-	242F2860/80	27/04/17
242F2830	Natural	PAV0	2x8w	02	-	Mat.15%GF	26/04/16
242F2810	Natural	PAV2	2x8w	01	-	Mat.7%GF /Fechador	16/06/14
				00	V.Roura	1ªEdición	06/03/14

Part Number	Finish	Material	Ways	Rev	Name	Modification	Date
242F2880	Natural	PAV2NF	2x8w	05	O.Roura	Update dimensions	21/05/26
242F2860	Natural	PAV0NF	2x8w	04	O.Roura	Suppress mat. 45 Version 3.5->3.7	24/04/26
242F2840	Natural	PAV2GFNF	2x8w	03	-	242F2860/80	27/04/17
242F2830	Natural	PAV0	2x8w	02	-	Mat.15%GF	26/04/16
242F2810	Natural	PAV2	2x8w	01	-	Mat.7%GF /Fechador	16/06/14
				00	V.Roura	1ªEdición	06/03/14

Part Number	Finish	Material	Ways	Rev	Name	Modification	Date
242F2880	Natural	PAV2NF	2x8w	05	O.Roura	Update dimensions	21/05/26
242F2860	Natural	PAV0NF	2x8w	04	O.Roura	Suppress mat. 45 Version 3.5->3.7	24/04/26
242F2840	Natural	PAV2GFNF	2x8w	03	-	242F2860/80	27/04/17
242F2830	Natural	PAV0	2x8w	02	-	Mat.15%GF	26/04/16
242F2810	Natural	PAV2	2x8w	01	-	Mat.7%GF /Fechador	16/06/14
				00	V.Roura	1ªEdición	06/03/14

Part Number	Finish	Material	Ways	Rev	Name	Modification	Date
242F2880	Natural	PAV2NF	2x8w	05	O.Roura	Update dimensions	21/05/26
242F2860	Natural	PAV0NF	2x8w	04	O.Roura	Suppress mat. 45 Version 3.5->3.7	24/04/26
242F2840	Natural	PAV2GFNF	2x8w	03	-	242F2860/80	27/04/17
242F2830	Natural	PAV0	2x8w	02	-	Mat.15%GF	26/04/16
242F2810	Natural	PAV2	2x8w	01	-	Mat.7%GF /Fechador	16/06/14
				00	V.Roura	1ªEdición	06/03/14

Part Number	Finish	Material	Ways	Rev	Name	Modification	Date
242F2880	Natural	PAV2NF	2x8w	05	O.Roura	Update dimensions	21/05/26
242F2860	Natural	PAV0NF	2x8w	04	O.Roura	Suppress mat. 45 Version 3.5->3.7	24/04/26
242F2840	Natural	PAV2GFNF	2x8w	03	-	242F2860/80	27/04/17
242F2830	Natural	PAV0	2x8w	02	-	Mat.15%GF	26/04/16
242F2810	Natural	PAV2	2x8w	01	-	Mat.7%GF /Fechador	16/06/14
				00	V.Roura	1ªEdición	06/03/14

Part Number	Finish	Material	Ways	Rev	Name	Modification	Date
242F2880	Natural	PAV2NF	2x8w	05	O.Roura	Update dimensions	21/05/26
242F2860	Natural	PAV0NF	2x8w	04	O.Roura	Suppress mat. 45 Version 3.5->3.7	24/04/26
242F2840	Natural	PAV2GFNF	2x8w	03	-	242F2860/80	27/04/17
242F2830	Natural	PAV0	2x8w	02	-	Mat.15%GF	26/04/16
242F2810	Natural	PAV2	2x8w	01	-	Mat.7%GF /Fechador	16/06/14
				00	V.Roura	1ªEdición	06/03/14

Part Number	Finish	Material	Ways	Rev	Name	Modification	Date
242F2880	Natural	PAV2NF	2x8w	05	O.Roura	Update dimensions	21/05/26
242F2860	Natural	PAV0NF	2x8w	04	O.Roura	Suppress mat. 45 Version 3.5->3.7	24/04/26
242F2840	Natural	PAV2GFNF	2x8w	03	-	242F2860/80	27/04/17
242F2830	Natural	PAV0	2x8w	02	-	Mat.15%GF	26/04/16
242F2810	Natural	PAV2	2x8w	01	-	Mat.7%GF /Fechador	16/06/14
				00	V.Roura	1ªEdición	06/03/14



MALE HOLDER
PITCH 4.2 mm – UPFIT
VALEO



DRAWN	V.Roura	06/03/14
REVISED	F.Adamuz	06/03/14
SCALE	2:1	⊕

MATERIAL STANDARDS	DIMENSIONAL STANDARDS	GENERAL TOLERANCES
Special	Special	±0,25

FORMAT	A3h
DRAWING	PTC-c596
REF.	242F28xx r04