

DETAIL B
SCALE 5 : 1

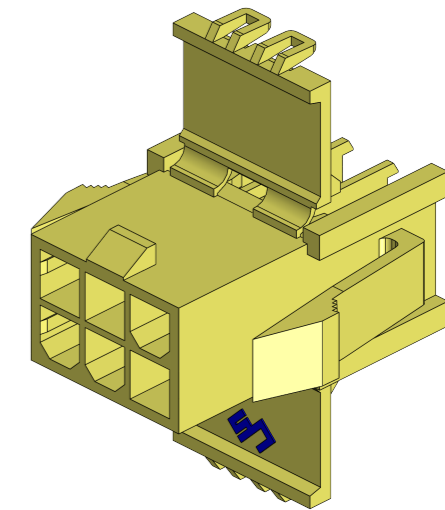

NOTES

GENERAL NOTES	
Refer to 3D for missing dimensions. In case of doubt, ask before interpretate any dimension.	
SYMBOLS DEFINITION	
⊗	Control dimension

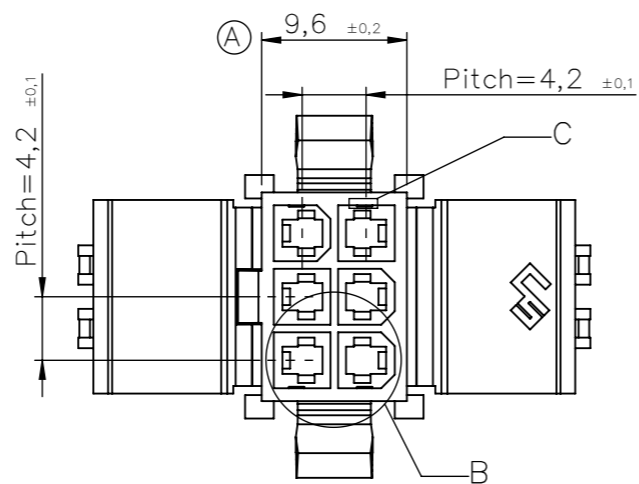
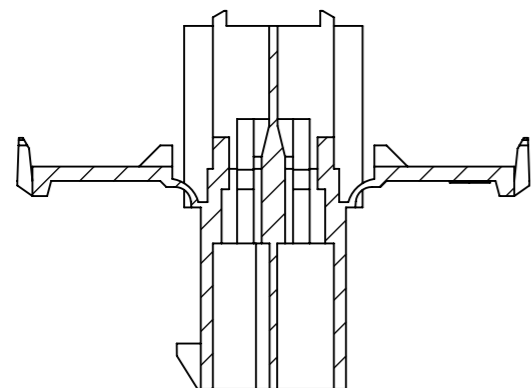

SECTION A-A

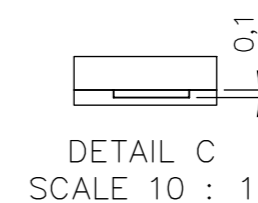
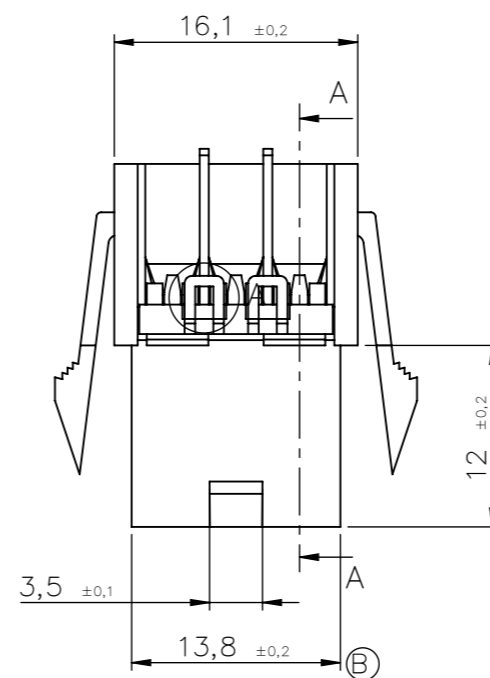
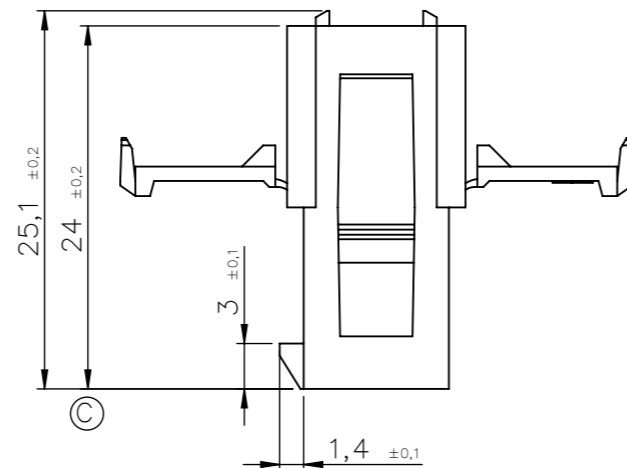

DETAIL C
SCALE 10 : 1

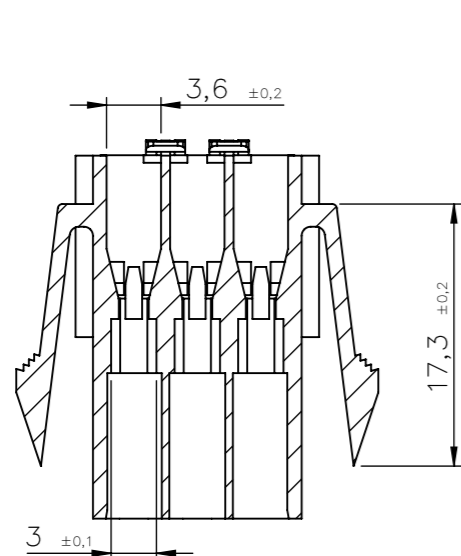

SECTION B-B

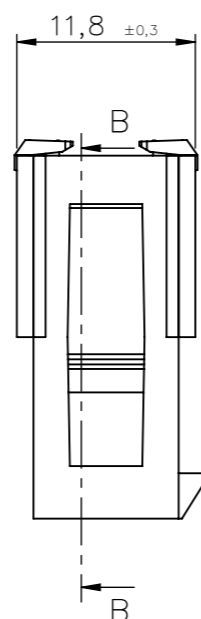

242FP2380	Natural	PAV2NF	2x3w	05	O.Roura	Suppress mat. 45 Version 3.5->3.7	22/12/25	
242FP2360	Natural	PAV0NF		04	-	242FP2360/80	27/04/17	
242FP2340	Natural	PAV2GFNF		03	-	Mat. 15%GF	26/04/16	
242FP2330	Natural	PAV0		02	-	Mat. 7%GF /Fechador	16/06/14	
242FP2310	Natural	PAV2		01	-	Añ.242FP2345	03/09/13	
				00	V.Roura	1º Edición	16/01/12	
Part Number	Finish	Material	Ways	Rev	Name	Modification	Date	
			PANEL MOUNT MALE HOLDER PITCH 4.2 mm – UPFIT					
DRAWN	V.Roura	16/01/12	MATERIAL STANDARDS		DIMENSIONAL STANDARDS		GENERAL TOLERANCES	
REVISD	F.Adamuz	16/01/12	Special		Special		±0,25	
SCALE	2:1		REF. 242FP23xx		r05			