

DETAIL B  
SCALE 5 : 1

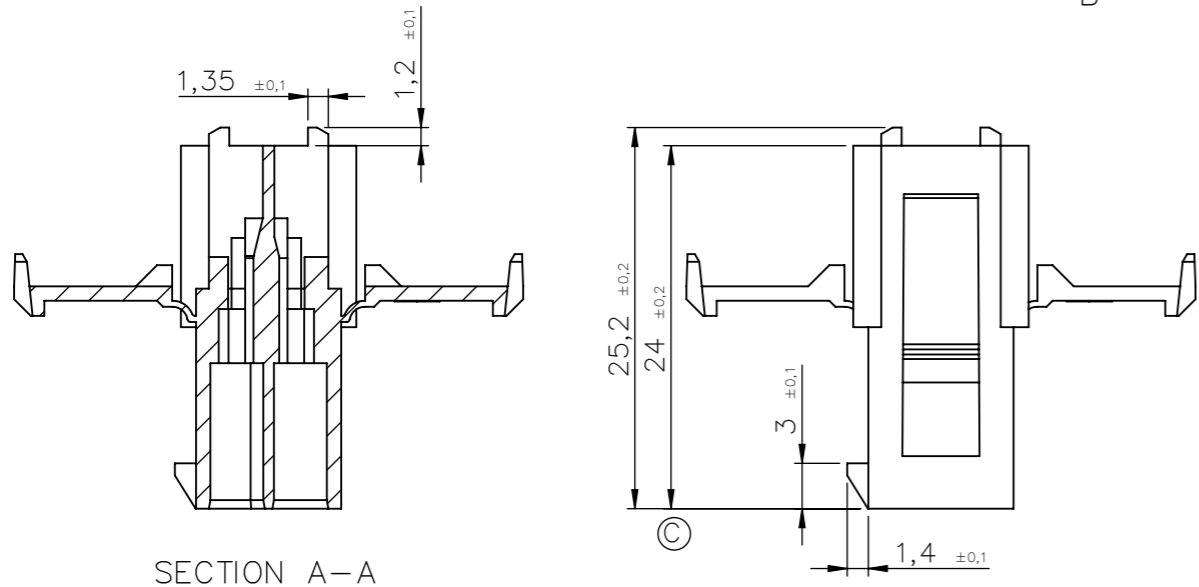

SECTION A-A

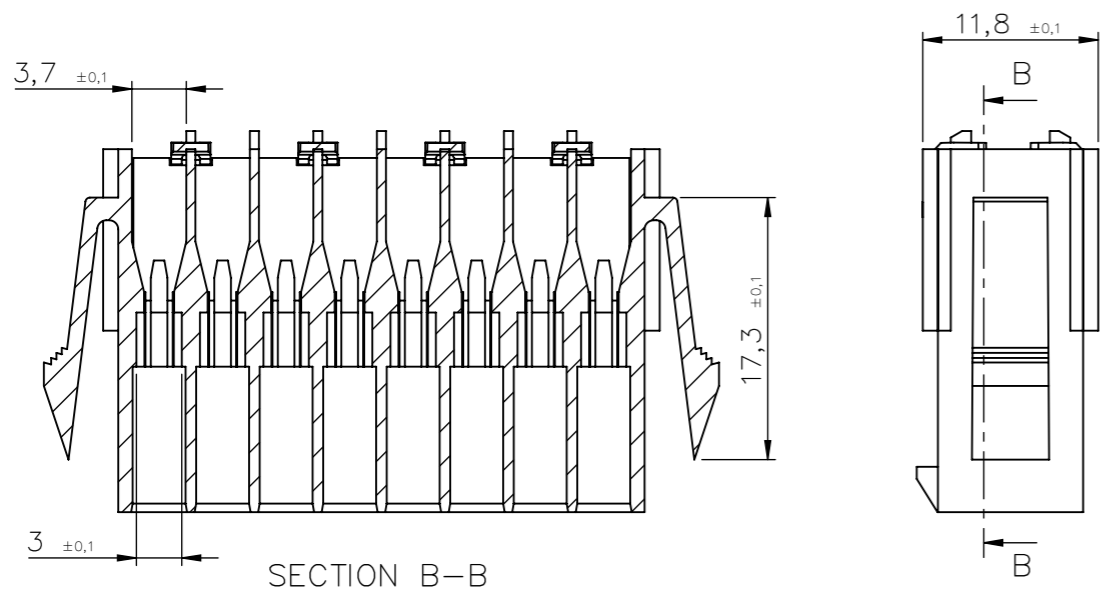
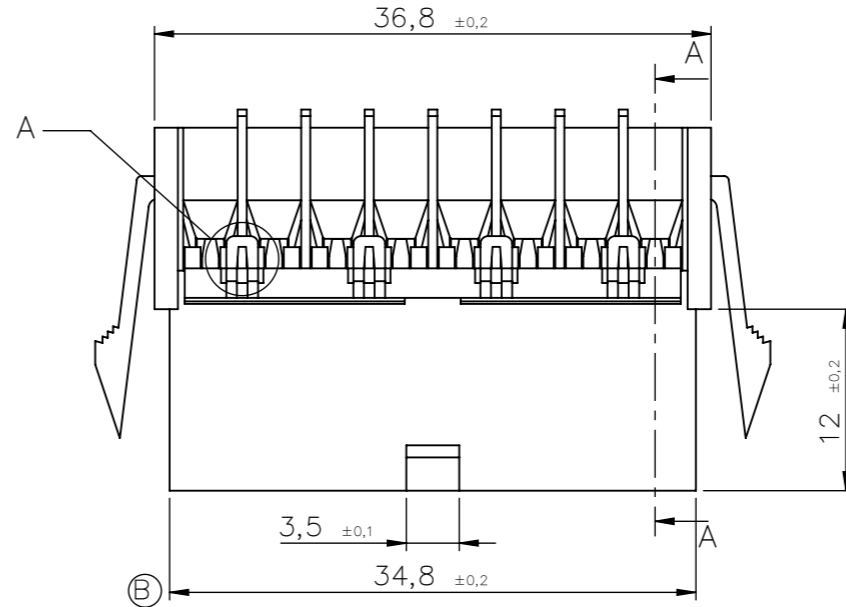

SECTION B-B

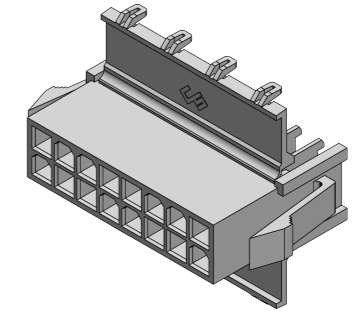

NOTES

GENERAL NOTES

Refer to 3D for missing dimensions. In case of doubt, ask before interpretate any dimension.

SYMBOLS DEFINITION

⊗ Control dimension

08	O.Roura	Update dimensions	21/05/26
07	O.Roura	Suppress mat. 45 Version 3.5->3.7	24/04/26
06	-	242FP2860/80	27/04/17
05	-	Mat.15%GF	26/04/16
04	-	Mat.7%GF/Fechador	16/06/14
03	-	Rev.cotas	11/07/13
02	-	Chanf.int.	24/06/13
01	-	Dimens.ancl.	10/12/12
00	V.Roura	1ªEdición	15/02/12

Part Number	Finish	Material	Ways	Rev	Name	Modification	Date
242FP2880	Natural	PAV2NF	2x8w	04	-	Mat.7%GF/Fechador	16/06/14
242FP2860		PAV0NF		03	-	Rev.cotas	11/07/13
242FP2840		PAV2GFNF		02	-	Chanf.int.	24/06/13
242FP2830		PAV0		01	-	Dimens.ancl.	10/12/12
242FP2810		PAV2		00	V.Roura	1ªEdición	15/02/12

Part Number	Finish	Material	Ways	Rev	Name	Modification	Date
				PANEL MOUNT MALE HOLDER PITCH 4.2 mm – UPFIT VALEO			
DRAWN	V.Roura	15/02/12	MATERIAL STANDARDS		DIMENSIONAL STANDARDS	GENERAL TOLERANCES	FORMAT
REVISD	F.Adamuz	15/02/12	Special	Special	±0,25		A3h
SCALE	2:1						DRAWING
							PTC-c580
							REF. 242FP28xx r08